



**PENTAIR**

**STA-RITE®**

# *enviroMAX*

1 1 0 0

VARIABLE SPEED POOL PUMP



Copyright © Pentair Australia Pty Ltd 2014



# FEATURES & BENEFITS

The Sta-rite enviroMAX is the ideal pump for new or existing pools. Utilising advanced hydraulic design and the latest technology in permanent magnet, variable speed motors, the Sta-rite enviroMAX has the perfect combination of efficiency and performance.

The Sta-rite enviroMAX delivers energy savings and the power when you need it. You will also have the peace of mind that you are doing your bit for the environment and reducing your carbon foot print.



- Variable speed pump, with 4 programmable speeds, allows you to effortlessly select the most efficient setting to meet your filtration, cleaning and water feature needs.
- Radial flux, brushless, permanent magnet motor delivers high efficiency low noise levels and servcability.
- Fault protected motor prevents damage by automatically shutting down the motor in the event of a locked rotor, under voltage, over voltage or over current condition and will automatically reduce the speed during an over temperature condition.
- Precision-fit internal components and superior hydraulic design deliver effortless performance, energy savings and extended pump life.
- Constructed of our durable, thermoplastic, composite resin, so you can be sure it will stand up to the harshest conditions.
- Step advance feature.
- The Cam and Ramp™ lid is easy to remove and locks in place with a quarter turn, making inspection and cleaning a breeze.
- The high-capacity trap holds a large amount of debris, so you clean less often. Quick-disconnect plumbing unions.



**SUPER EFFICIENCY RATING**

The more stars the more energy efficient

**ENERGY RATING**

A joint government and industry program  
**STA-RITE ENVIROMAX**  
Variable Speed

Efficiency L/W/h	Flow Rate L/min	Head m	Power W	Noise dBA
46.3	133.7	3.2	173.5	

Energy consumption  
**395**  
kWh per year  
To pump 50,000 litres/day





# WITH RESPECT TO THE ENVIRONMENT



## THE GREEN...ENERGY SAVER...

The ENVIROMAX 1100 is an environment friendly / energy saving pool pump. Using advanced variable speed technology it will use significantly less power compared to a conventional pool pump, resulting in lowering your carbon footprint, while saving you thousands of dollars in operating costs at the same time.



## THE BENEFITS OF VARIABLE SPEED & STEP TECHNOLOGY

The ENVIROMAX 1100 uses a radial flux, brushless, permanent magnet motor which offers high efficiency levels compared with conventional induction motors. Combined with the latest in electronic control, this allows the motor/pump to run at varying speeds.

Step technology, allows you to select a duration for each speed setting and automatically switches to the next speed/step after the time is up. This allows you to fine tune your pool filtration and circulation and get the most from your variable speed pump.

SLASH ENERGY USE BY **70%**  
AND **SAVE**

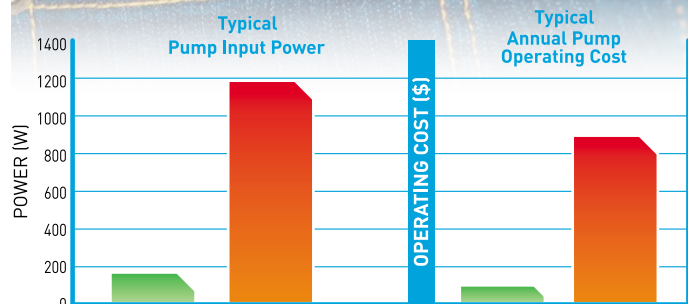

Legend:  
■ ENVIROMAX at low speed  
■ Conventional 1.5hp pump

Other pumps		Sta-Rite ENVIROMAX 1100		
Existing Pump	Annual operating cost*	Annual operating cost	Annual saving	Annual reduction in CO <sup>2</sup> emissions
1.5HP	\$1058	\$85	\$972	3363Kg
1.0HP	\$762	\$85	\$676	2239Kg

\* Calculation based on typical pump performance data with running time of 8hrs per day, 365 days per year and \$0.29 per kW/hr. ENVIROMAX cost based on running time for 1 turnover of a 75,000L pool and off-peak rates \$0.14 kW/hr. Actual savings will vary depending on pool system configuration and usage. Pentair takes no responsibility if advertised savings are not achieved.





	STEP 1	STEP 2	STEP 3	VERRIDE
<b>RPM</b>	2600	2100	1600	600-3450
<b>Max. motor input power P1</b>	690W	375W	180W	1375W
<b>Max. motor output power P2</b>	550W	300W	145W	1100W
<b>Max. Current</b>	5.4A	3.2A	1.7A	10A
<b>Voltage</b>	230-240VAC 50Hz Single phase			
<b>Max. Rating</b>	3450RPM, P1 1375W, P2 1100W, 10.0A			
<b>Motor type</b>	Radial flux, permanent magnet, DC			
<b>Ingress protection</b>	IP25			
<b>Inlet connection</b>	ABS Barrel Union to suit 50mm PVC pressure pipe to AS/NZS 1477			
<b>Outlet connection</b>	ABS Barrel Union to suit 50mm PVC pressure pipe to AS/NZS 1477			
<b>Max. Water temperature</b>	40°C			
<b>Max. Ambient temperature</b>	55°C			
<b>Sound power level (Lwa)</b>	LOW: 69dB - MED.: 63dB - HIGH: 57dB - OVRD: 73dB			

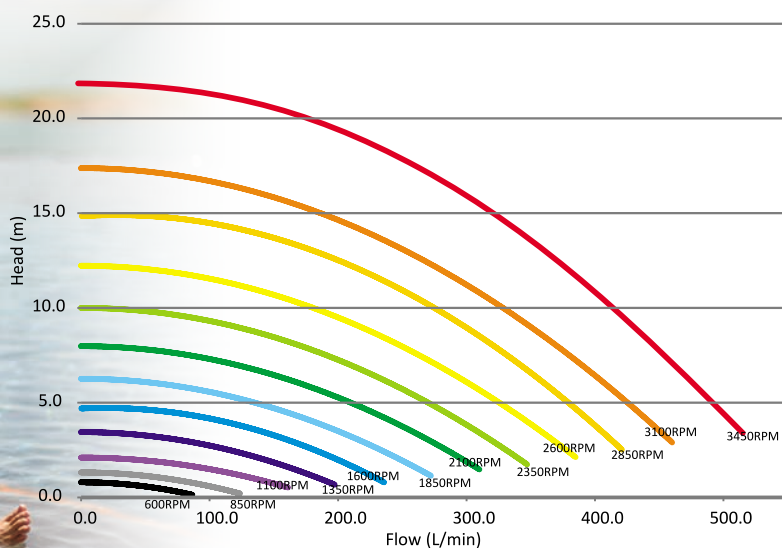
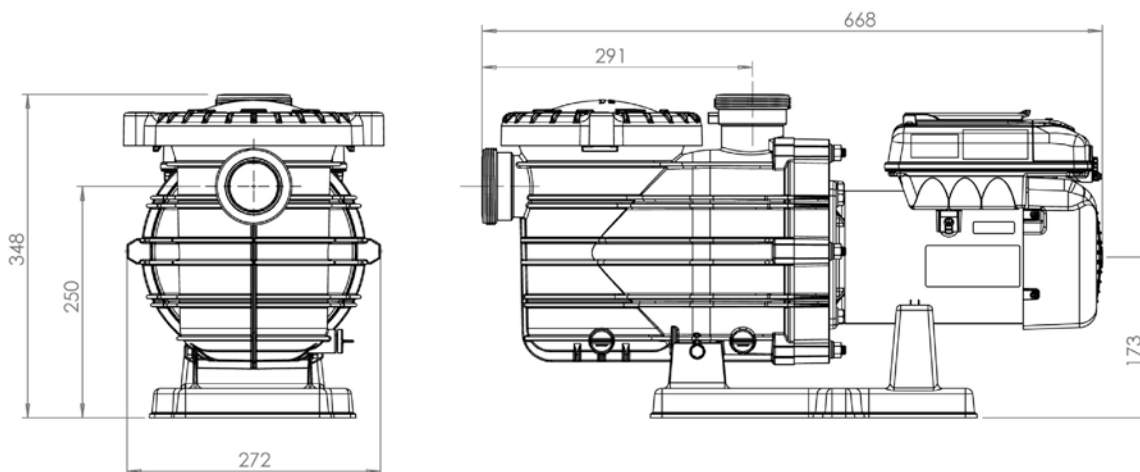

AVAILABLE FROM:



## AQUATIC SYSTEMS

1-21 MONASH DRIVE, DANDENONG SOUTH, VIC 3175 1300.137.344 WWW.PENTAIRPOOL.COM.AU

All Pentair trademarks and logos are owned by Pentair or one of its global affiliates. MasterTemp® and Eco Select® are registered trademarks of Pentair Water Pool and Spa, Inc. and/or its affiliated companies in the United States and/or other countries. Because we are continuously improving our products and services, Pentair reserves the right to change specifications without prior notice. Pentair is an equal opportunity employer.

pumps • filters • heaters • heat pumps • automation • lighting • cleaners • sanitizers • water features • maintenance products

Part L300247 A1114 ©2014 Pentair Australia Pty. Ltd., All rights reserved.

