



PuraShield[®] UV

PuraShield[®] UV + O₃

ADVANCED SANITISERS

OWNER'S MANUAL



Should the installer or owner be unfamiliar with the correct installation and/or operation of this type of equipment, please contact the distributor or manufacturer for the correct advice before proceeding with the installation or operation of this product.

IMPORTANT

Please attach your sales invoice/docket here as proof of purchase should warranty service be required. Please do not return warranty form to Pentair Australia - Retain for your records.

PURCHASED FROM:
PURCHASE DATE:
SERIAL NO:
MODEL NO:

TABLE OF CONTENTS

1. SAFETY WARNINGS	2
2. INTRODUCTION	3
2.1 Secondary Sanitisers	3
2.2 Ultraviolet Disinfection	3
2.3 Ozone Disinfection	4
2.4 Main Advantages	4
3. TECHNICAL SPECIFICATIONS	5
3.1 Performance Data	5
3.2 Dimensions	5
4. INSTALLATION	6
4.1 Plumbing Installation	6
4.2 Equipment Layout	6
4.3 Installation Options	9
4.4 Flow Switch Installation	9
4.5 Flow Switch Orientation	10
4.6 Bypass Guide	10
4.7 Venturi Installation Guide	12
5. START UP & ADJUSTMENTS	13
5.1 Preparation	13
5.2 Water Chemistry	13
5.3 UV Transmittance	13
6. OPERATION	14
6.1 Power On	14
6.2 Digital Timer	14
6.3 UV Lamp Lifetime Meter	14
6.4 Clock Setting	15
6.5 Schedule Timer Setting	15
6.6 Flow Switch	15
7. MAINTENANCE	16
7.1 Lamp & Quartz Glass Maintenance / Replacement	16
7.2 Stainless Steel Housing Maintenance	17
7.3 Electrical Unit Replacement	17
8. TROUBLESHOOTING	20
9. SPARE PARTS	21

1. SAFETY WARNINGS



ATTENTION

Before installing the UV Sanitiser, please read this manual carefully. If you need to clarify any point or have any doubts, please contact your dealer.

This installation and operation manual includes important instructions to installers and users. It must be installed and serviced by a qualified pool and spa technician in accordance with the corresponding electrical and plumbing codes. It is recommended that the owner and operator keep this manual for reference.

IMPORTANT:

The instruction manual you are holding includes essential information on the safety measures to be implemented for installation and start-up of this appliance. Therefore, the installer as well as the user must read the instructions before beginning installation and start-up.

This device is intended for swimming pools and spas only; do not use it for potable water sanitation (drinking water). The system must be connected only to a supply circuit that is protected by a Residual Current Device (RCD), otherwise operation could result in electrical shock causing serious bodily injuries, including death.

This appliance is not intended for use by persons (including children) with reduced physical, sensory or mental capabilities, or lack of experience and knowledge, unless they have been given supervision or instruction concerning use of the appliance by a person responsible for their safety.

Children should be supervised to ensure that they do not play with the appliance.

If the supply cord is damaged, it must be replaced by the manufacturer, its service agent or similarly qualified persons in order to avoid a hazard.

The following safety instructions have to be taken into consideration when installing or using this ultraviolet disinfection system:

1. Disconnect all power supplies during installation.
2. Do not operate the ultraviolet system if the power supply lead is damaged.
3. Replace damaged cords immediately.
4. To avoid possible electrical shock, special care should be taken keeping all connections dry and off the ground. Do not touch the plug with wet hands.
5. For each of the following situations, do not attempt to repair the appliance on your own; return it to an authorised service facility for repair:
 - If the appliance falls into the water, DO NOT reach for it! First unplug it and then retrieve it. If electric components of the appliance get wet, unplug the appliance immediately.
6. Do not operate this UV-C system if interconnecting wires are damaged.
7. Never look at the UV Lamp directly while it is operating, as it may cause eye injury, burns, or even blindness.
8. Lamps and quartz sleeves are extremely delicate. Care should be taken when handling or replacing these components:
 - Wear cotton gloves when handling lamps or sleeves.
 - Hold bulbs by the ends only and never touch the glass with bare hands, since it would leave dirt which would reduce the working life.
 - If any fingerprint is left, clean it with isopropyl alcohol.
9. Allow the ultraviolet lamps to cool before handling.
10. Make sure that the nut, the washer and the O-Ring are correctly positioned, otherwise the quartz sleeves could be expelled from their holder at speed and injure you.
11. Special safety warning must be taken into consideration for the model PuraShield UV-C Ozone system:
12. The UV Lamp generates ozone that emits a strong odour, even in very small quantities, and can be harmful for eyes, nose and skin.
13. Check the system for any leakage. A proper installation and the correct position of the sealing rings are of crucial importance.

2. INTRODUCTION

2.1 Secondary Sanitisers

Ozone and UV-C are two of the most efficient disinfection processes in water treatment. PuraShield UV uses UV exposure only and PuraShield UV + O₃ (Ozone) mixes these two concepts in one unique appliance which will help keep your swimming pool water fresh, crystal clear and disinfected, reducing the use of chlorine to a minimum.

UV and Ozone are intended to be secondary sanitisers. This means that they are designed to work in conjunction with, not instead of, the primary sanitiser. Typically the primary sanitiser will be a salt water chlorinator, or a liquid or dry chlorine feeder.

PuraShield enhances the effectiveness of the pool sanitation system by taking care of part of the disinfection process, in removing some chlorine resistant bacteria and pathogens, but also removing some of the byproducts of the chemical sanitation process (e.g. chloramines).

2.2 Ultraviolet Disinfection

Ultraviolet technology is a non-chemical approach to disinfection. In this method of disinfection, no chemicals are added to the water which makes this process safe, simple, inexpensive and requires very low maintenance. UV-C light is becoming increasingly favoured by the pool industry due to its ability to not only disinfect the water but also break down and remove chloramines, which can cause eye, skin and nose irritation, and breathing difficulties.

The PuraShield UV disinfection systems uses UV-C ultraviolet rays to irradiate target bacteria. At predetermined values of UV-C exposure, permanent damage to the bacteria DNA occurs, effectively sterilising the organism

UV light is comprised of electromagnetic radiation of wavelengths ranging from 10 nm to 400 nanometres (nm). UV-C (Short Wave UV): 200-280 nm. 254nm is the predominant UV-C wavelength used by PuraShield. The 254 nm wavelength penetrates the cell wall of the micro-organism. The UV energy permanently alters the DNA structure of the micro-organism in a process called thymine dimerization. The micro-organism is not destroyed it is "sterilized" and rendered unable to reproduce.

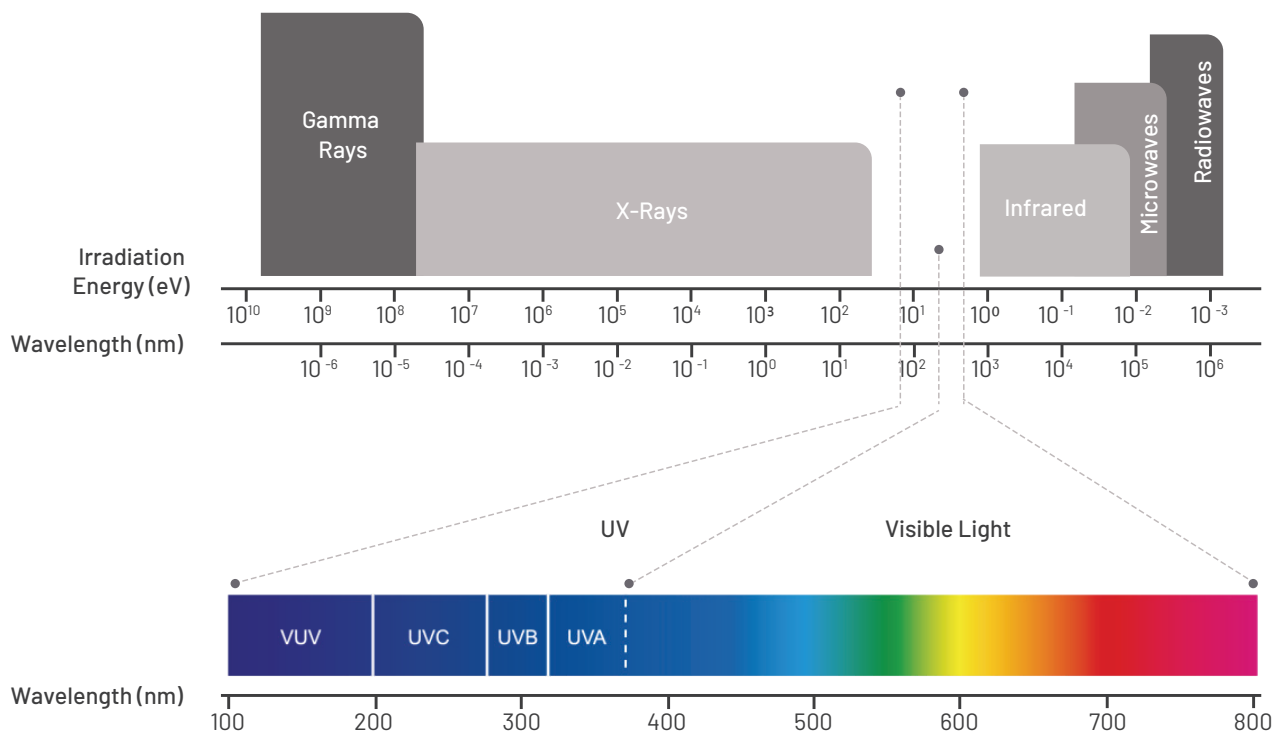

Figure 1. UV dose of 30mJ/cm² is sufficient for disinfection of the water and protection against 99.9% of chlorine-resistant micro organisms.

2. INTRODUCTION

2.3 Ozone Disinfection

PuraShield UV & Ozone systems contain a high intensity Ultraviolet lamp different from the other UV models. This special lamp emits two separate wavelengths within the UV spectrum: 254nm and 185nm. While the 254nm wave deactivates the DNA of bacteria, viruses and other pathogens, the 185 nm wave is responsible for converting the oxygen contained in the quartz sleeve area into ozone.

The ozone produced is introduced into the water stream by venturi effect. Finally, the Ozone and the ultraviolet radiation will work together to destroy micro-organisms such as moulds, Legionella bacteria, parasites, algae or viruses, and can also break down urine, sweat, cosmetics and sun cream particles without leaving any harmful by-products (**Figure 2**).

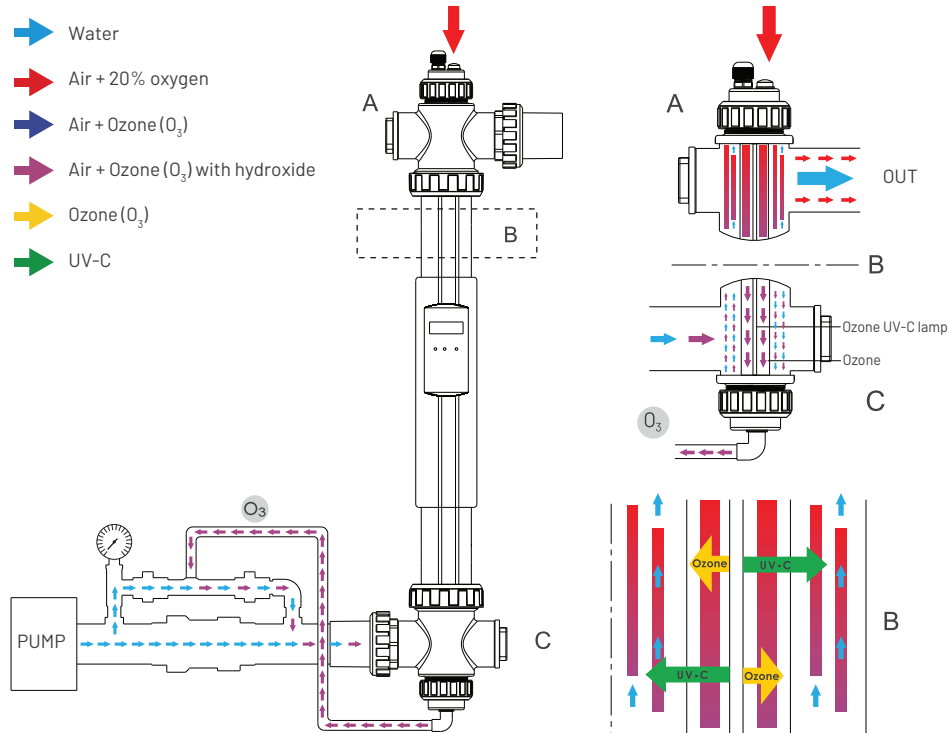

Figure 2. UV + Ozone System Flow Diagram.

2.4 Main Advantages

Ultraviolet Advantages	Ozone Advantages (only PSUV-87-03)
<ul style="list-style-type: none"> • Protects your pool against pathogenic organism and algae. • Environmentally friendly. • No risk of allergies. • Non-irritating to skin. • Corrosion and odour-free. • Reduces chlorine consumption. • UV-C lamp life of 9,000 hours. • Amalgam lamp (130W only) 12,000 hours. • Countdown timer indicates when the lamp must be replaced. • Housing with mirror polished Stainless Steel AISI-316L that increases the UV-C radiation reflection, thereby increasing the efficiency up to 35%. • Easy installation and maintenance. 	<ul style="list-style-type: none"> • Protects your pool against pathogenic organism and algae. • Environmentally friendly. • No risk of allergies. • Non-irritating to skin. • Reduces chlorine consumption. • Ozone lamp life of 10,000 hours. • Countdown timer indicates when the lamp must be replaced. • Urine, sun cream, cosmetics and transpiration particles are broken down by ozone. • Low maintenance. • Cost-saving.

3. TECHNICAL SPECIFICATIONS

3.1 Performance Data

	PuraShield UV + O₃ PSUV-87-03	PuraShield UV PSUV-75	PuraShield UV PSUV-130
Main Feature	UV + Ozone	UV	UV
Power supply NT-UV40	220-240V, 50 / 60Hz	220-240V, 50 / 60Hz	220-240V, 50 / 60Hz
Input power	87W	75W	130W
Maximum working pressure	300 kPa	300 kPa	300 kPa
Maximum flow rate (40mJ/cm ²)*	175	200	275
Maximum flow rate (60mJ/cm ² **)	117	133	183
Connection size	40mm / 50mm (AS/NZS)	40mm / 50mm (AS/NZS)	40mm / 50mm (AS/NZS)
Low pressure lamp wavelength	254nm + 185nm	254nm	254nm Amalgam
Lamp lifetime	10,000 hours	9,000 hours	12,000 hours
Lamp type	GH0843T5VH	TUV 36T5 HO 4P SE	Amalgam UV-C lamp TUV 130W XPT SE
IP Protection	IP 54	IP 54	IP 54
Maximum Ozone production	0.6 g/hr	N/A	N/A

* 40mJ/cm² - Inactivation of Cryptosporidium and other chlorine tolerant pathogens.

** 60mJ/cm² - Additional breakdown of Chloramines for greatly improved air and water quality.

3.2 Dimensions

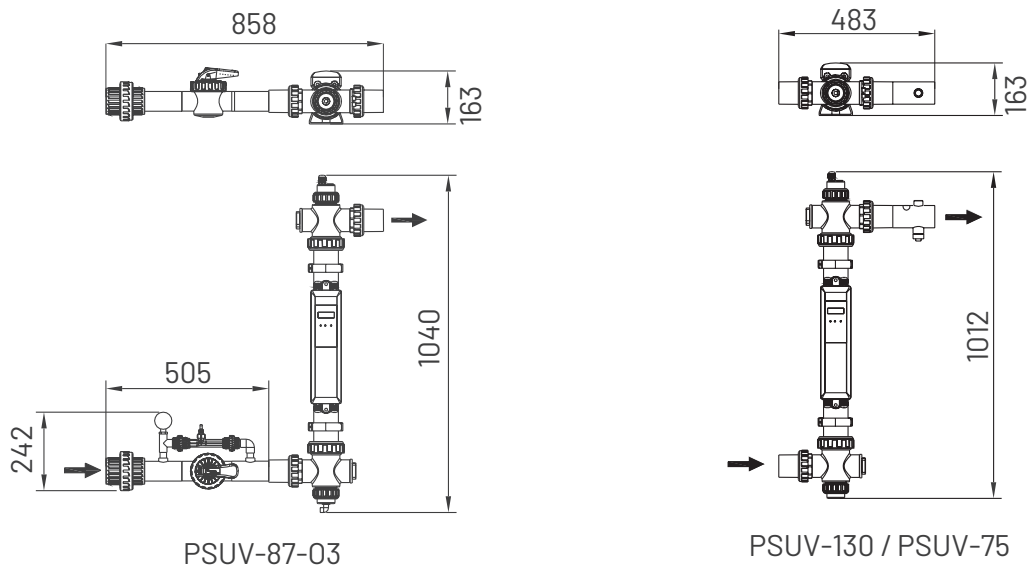

4. INSTALLATION

Install the unit taking into consideration the access and space for servicing, in a position where the lamp can be taken out easily. It is important to choose your disinfection system according to the flow rate required for the installation. If water passes through the unit too fast, the exposure time required for its maximum efficiency will be not enough. For this reason, the ultraviolet equipment selected for your pool should surpass the maximum flow rate of your filtration system pump. We also recommend to install the unit in a by-pass.

4.1 Plumbing Installation

	<p>It is recommended to use the same power source for UV-C system and the filtration pump such that they can be powered ON / OFF simultaneously to prevent no water flow for UV-C lamp cooling inside the stainless steel cylinder.</p> <p>This UV-C disinfection system comes with all internal components assembled and it is ready to be installed. Only pipes connections should be made before starting up the equipment.</p>
---	--

To achieve the correct installation, please follow the recommendations listed below:

1. Never install the PuraShield system in an area exposed to full sunlight. This equipment must be installed in a dry and ventilated area.
2. The PuraShield system must be wall mounted leaving a minimum space of 30cm underneath and 1.5meters at the top of the equipment for servicing and replacing the lamp.
3. The PuraShield system will need to be plumbed into the swimming pool / spa / water feature circuit always after the filter and before salt chlorine generator and pH regulator (if any).
4. If the filtration pump exceeds the maximum flow rate allowed for the PuraShield system, a by-pass circuit will be required.
5. Fit the PuraShield system with the supplied clamps in a fixed position and hand-tighten the 3 part couplings. Never use a wrench, tongs or other tools to tighten synthetic parts.
6. Glue the union connections to the filtration system's PVC pipes.
7. Activate the pump and check that there is not any leakage in the circuit.

4.2 Equipment Layout

	<p>When the PuraShield and a chlorinator are put together as disinfection system, the PuraShield should be placed before Chlorinator. I.e. the UV sanitiser must be installed upstream of the chlorinator.</p> <p>PuraShield UV products are not recommended to be used in seawater or seawater-like environments with high salt content as the stainless steel body will be corroded and leak in long term operation.</p> <p>Ozone will affect the ORP reading of the pool. Do not use an ORP controller or ORP controlled salt chlorinator when using ozone. The ozone will alter the ORP reading on the controller.</p>
---	--

4. INSTALLATION

4.2.1 UV System

The water circulation flows from the swimming pool skimmer to the pump to the filter. Position the PuraShield UV disinfection unit after the filter and before chlorinator. pH or ORP probes (if present) should be mounted after the filter and before the UV sanitiser. Salt chlorine generators and chemical dosing, such as acid or chlorine, must be after the PuraShield. If the system flow rate exceeds the maximum flow rate, you must use a bypass (refer to section 4.6).

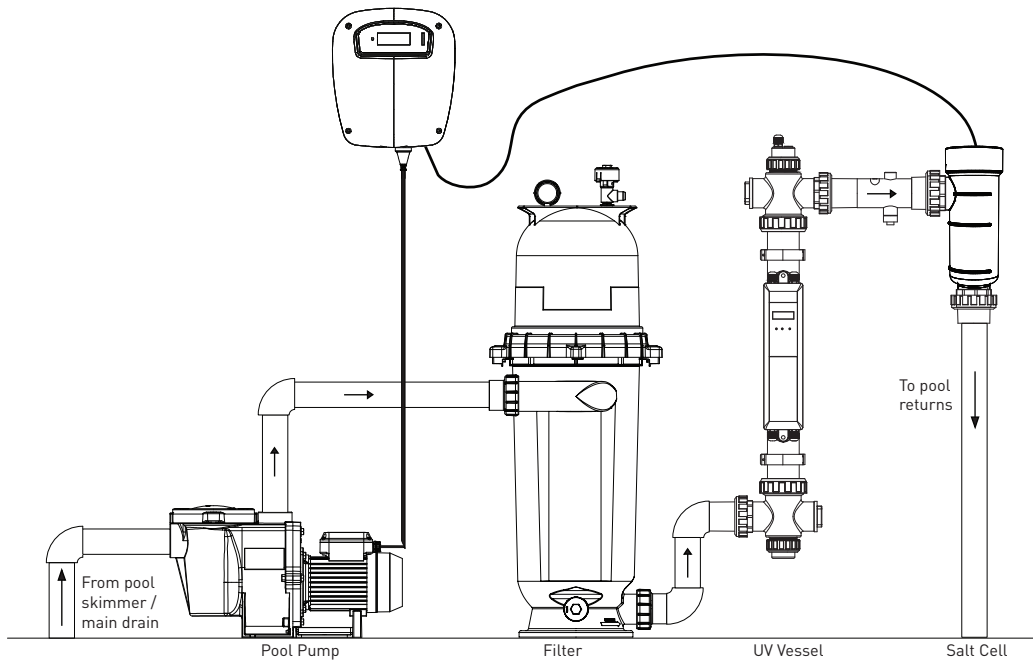

Figure 3. Basic Installation Diagram for UV Unit. Only if flowrate less than maximum flow rate (ref Section 3.1). **Use Bypass if greater than maximum flow rate.**

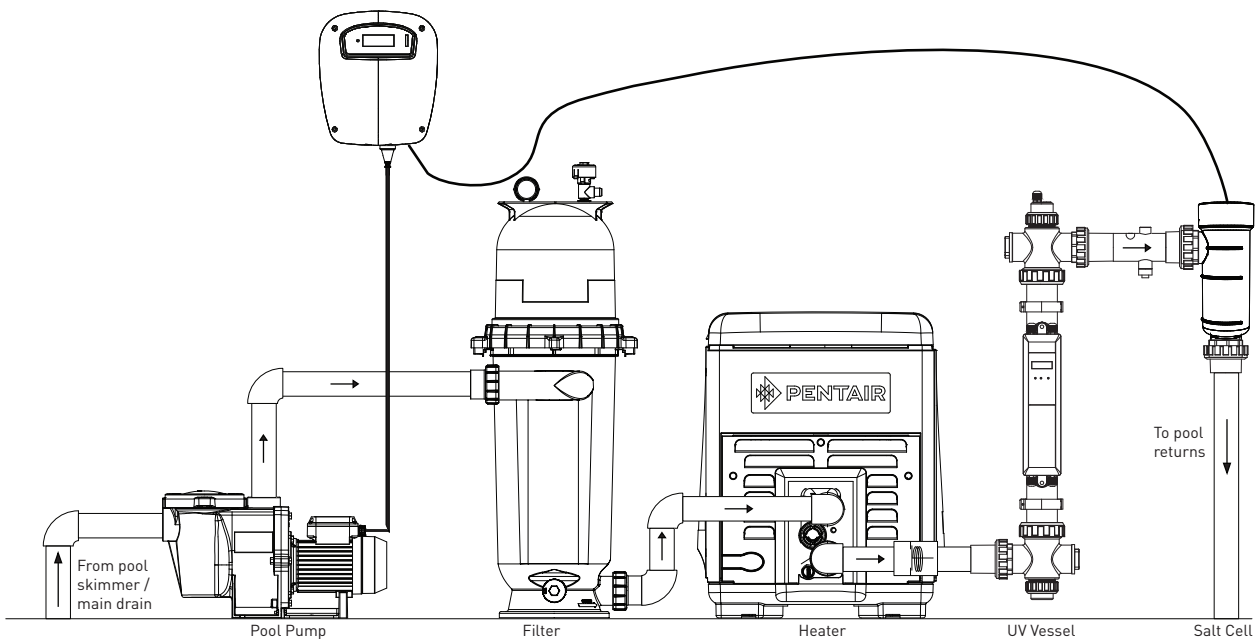

Figure 4. Basic Installation Diagram for UV Unit with a Heater. Only if flowrate less than maximum flow rate (ref Section 3.1). **Use bypass if greater than maximum flow rate.**

4. INSTALLATION

4.2.2 UV System With Ozone

The water circulation flows from the swimming pool skimmer to the pump to the filter. Position the PuraShield UV + Ozone disinfection unit after the filter and before chlorinator. pH probes (if present) should be mounted after the filter and before the UV sanitiser. Salt chlorine generators and chemical dosing, such as acid or chlorine, must be after the PuraShield. If the system flow rate exceeds the maximum flow rate, you must use a bypass (refer to section 4.6).

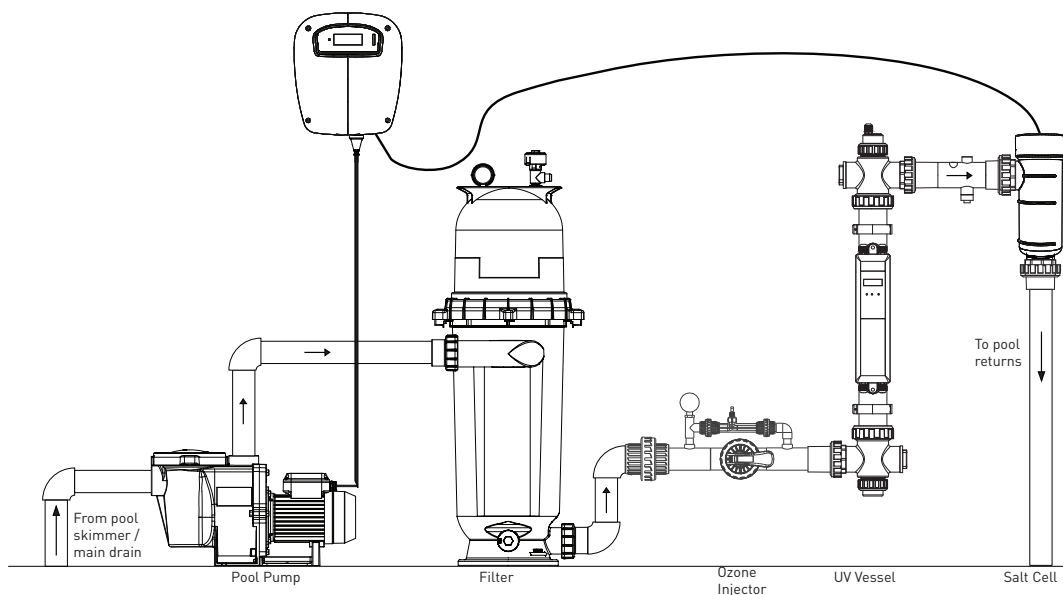

Figure 5. Installation Diagram for UV + Ozone Unit. Only if flowrate less than maximum flow rate (ref Section 3.1). **Use bypass if greater than maximum flow rate.**

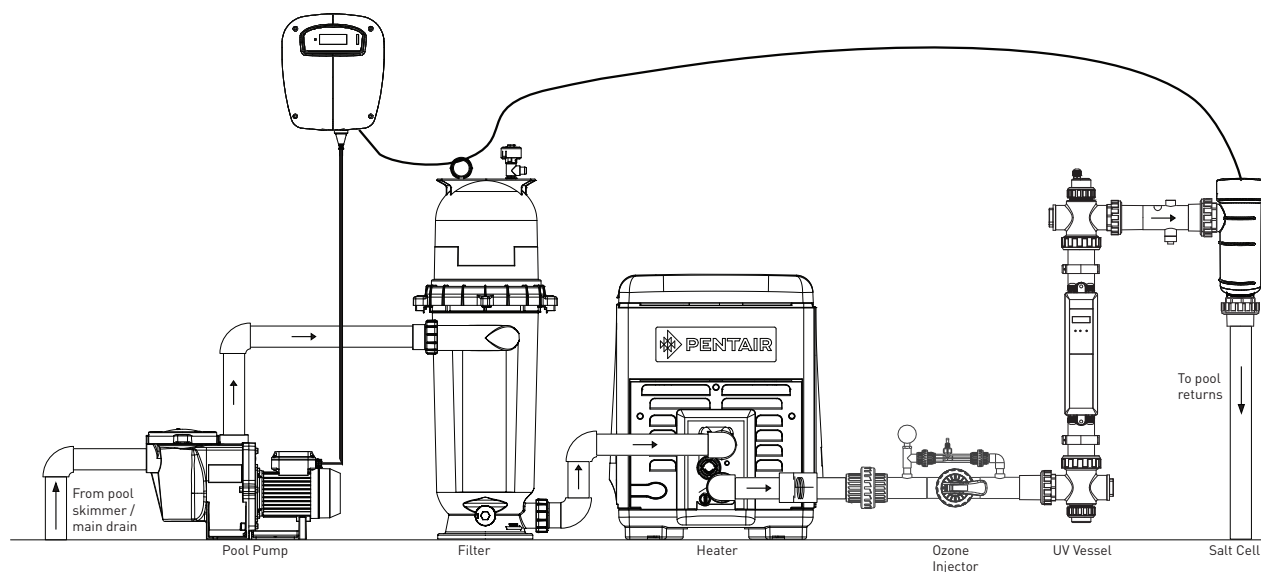

Figure 6. Installation Diagram for UV + Ozone Unit with a Heater. Only if flowrate less than maximum flow rate (ref Section 3.1). **Use bypass if greater than maximum flow rate.**

4. INSTALLATION

4.3 Installation Options

The translucent end cap and union sets are interchangeable for all models, they can be placed on either side. It is necessary to place and tighten the O-ring properly to prevent water leakage when doing relocation. There are two sets of 40mm (1.5") and 50mm (2") unions which can be fitted onto AS/NZS 1477 PVC pipe.



Transparent end cap with o-ring



Union with O-ring set



1.5" and 2" union

Figure 7. Barrel union fittings.

Horizontal installation is possible, for the UV only system, but the flow switch must be horizontal, or pointing upwards if vertical. For the UV + Ozone system, the UV vessel should only be orientated vertically so that it acts as a contact vessel for the ozone and enhances solution of the ozone in the pool water.



Figure 8. UV vessel in horizontal installation.

Vertical installation is recommended. The vessel can be wall mounted with the clamps provided. If no wall is available, a post must be installed to support the vessel. Do not let the pipework support the vessel.

4.4 Flow Switch Installation

The flow switch location is to fit into the actual water flow direction. It can be placed on the inlet or outlet, left side and right side, but it must point in the direction of the water flow and be in the same water circuit as the UV vessel.

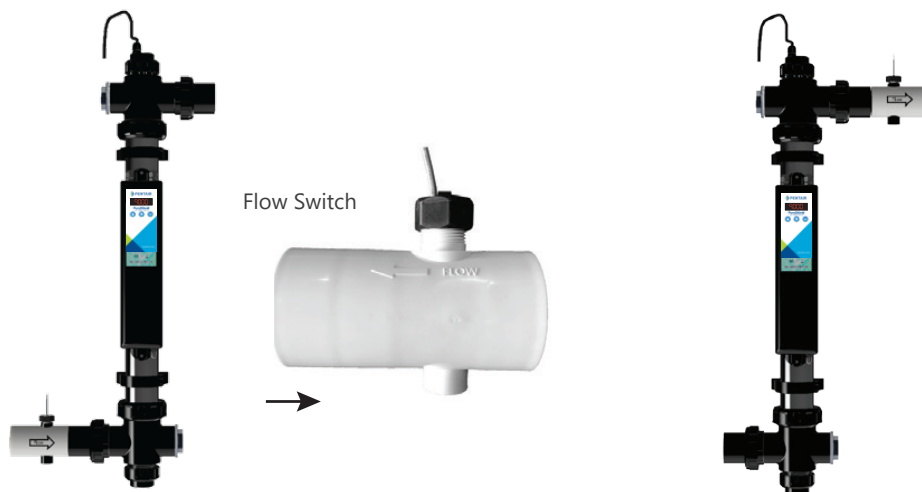

Figure 9. Flow switch positioning. It can be at either port but must align with flow.

4. INSTALLATION

4.5 Flow Switch Orientation

The flow switch should be installed horizontally in the direction of water flow, where possible. The flow switch can also be orientated vertically as long as the direction of flow is upward. Never locate the flow switch vertically where the direction of the flow is downward.

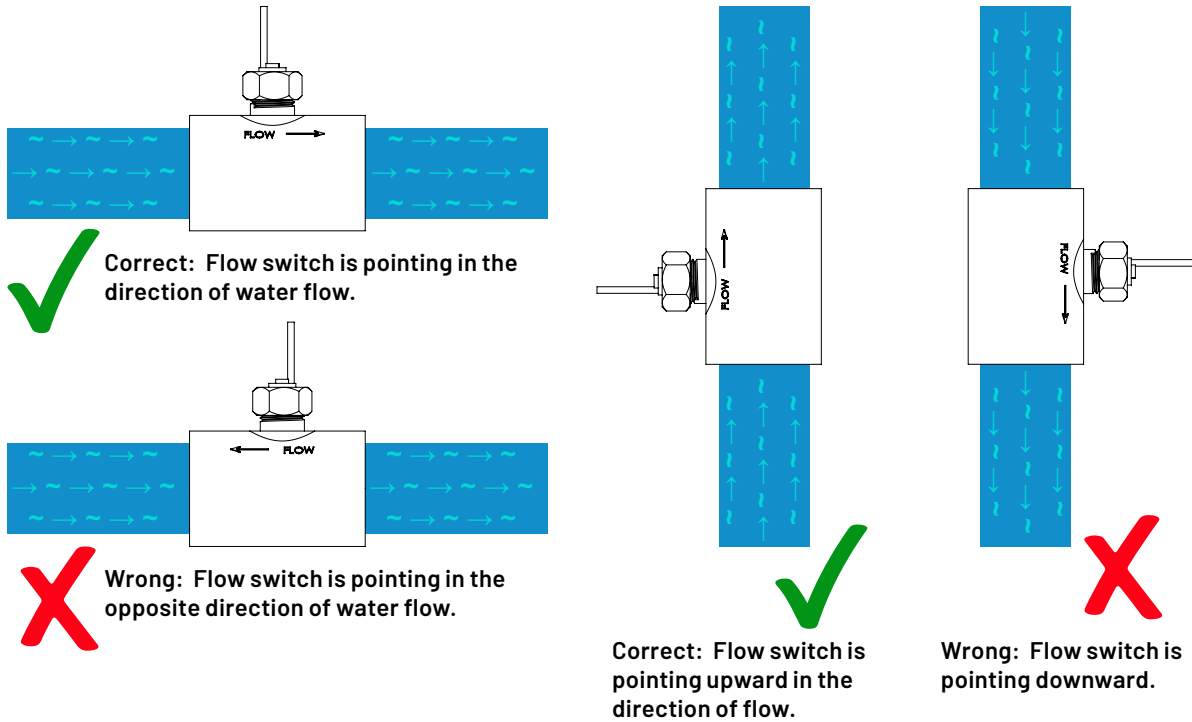

Figure 10. Flow switch orientation.

4.6 Bypass Guide

If the system flowrate exceeds the maximum flowrate for the desired UV exposure, then the PuraShield UV or PuraShield UV + Ozone needs to be installed on a bypass line. If the flowrate through the UV vessel exceeds the maximum flowrate, then the UV dosage will be insufficient and ineffective, so it is important to use the bypass where required. It is also important to ensure correct orientation of the flow switch in the bypass plumbing. Please see the diagrams below for suitable bypass plumbing.

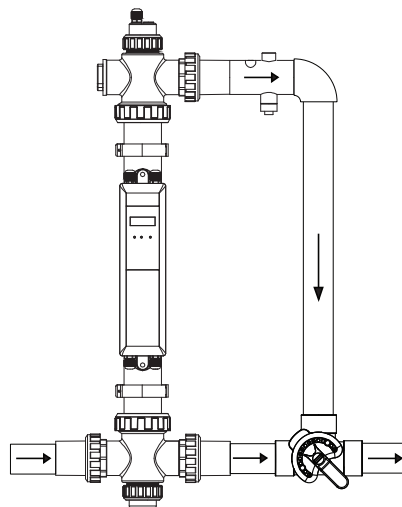

Figure 11. Bypass arrangements for PuraShield UV.

4. INSTALLATION

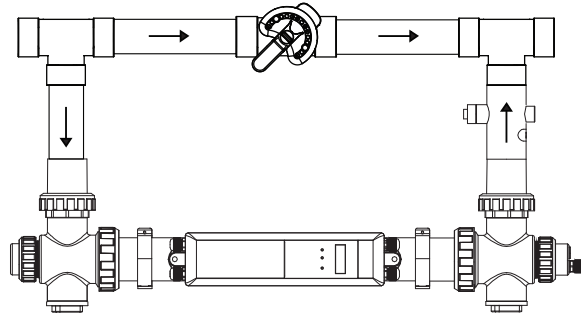

Figure 12. Bypass arrangements for PuraShield UV + Ozone.

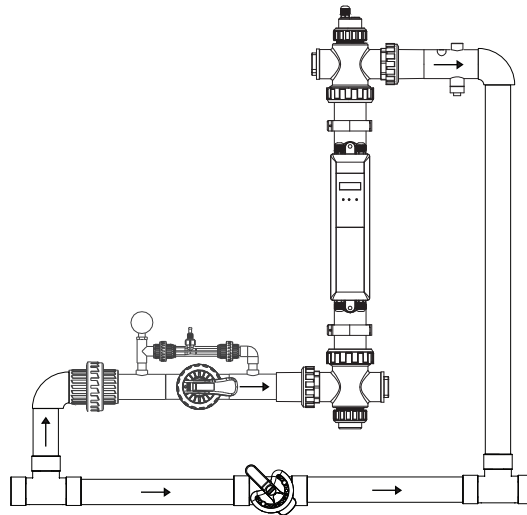

Figure 13. Bypass arrangements for PuraShield UV + Ozone.

5. START UP & ADJUSTMENTS

5.1 Preparation

Before starting up the PuraShield system, perform the following actions:

1. Backwash and rinse the sand filter or in the case of cartridge filter, clean the cartridge(s) and make sure it/they are completely clean.
2. Empty the leaf basket of the skimmer and the filtration pump.
3. Check the hydraulic connections and ensure there is no leakage.
4. Release the air from the circuit through the air relief valve installed on the filter (if equipped).

5.2 Water Chemistry

Proper chemical balances are necessary for sanitary bathing conditions as well as ensuring your PuraShield's long life. Be sure to keep your chemical and mineral concentration levels within the values indicated in the table below. Failure to maintain proper water chemistry may cause damage to the PuraShield and may void the warranty.

Test	Recommended Level
Free Chlorine	1.0 to 3.0 ppm
Bromine	2.0 to 4.0 ppm
pH	7.2 to 7.6
Total Alkalinity (TA)	80 to 120 ppm
Calcium Hardness (CH)	Ideally less than 120ppm as calcium can cause fouling of the quartz sleeve. Typical recommendation for CH is 200-400ppm. Consult your pool professional if you have high calcium.
Cyanuric Acid (Stabiliser)	30 to 50 ppm <i>(Less than 30ppm with ORP controllers)</i>
Total Dissolved Solids (TDS)	Less than 5,000 ppm
Turbidity	Less than 1NTU
Copper and Iron	0 to 0.2 ppm

* Concentration levels taken from "Basic Pool and Spa Technology" published by NSPI (National Spa and Pool Institute).

5.3 UV Transmittance

UVT or Ultraviolet Transmittance is defined as the % of UV light at 254nm that can transmit through 1cm of the pool water. UVT is a measure of how well the water is able to transmit UV light. It affects the intensity of light reaching the target pathogens. The lower the UVT, the less UVC light a pathogen receives.

UVT is affected by various compounds in the water that are able to absorb UV, including copper, iron, and anything else that can absorb UV-C. UV transmittance is not turbidity, the water's visual clarity is not an effective indicator, because both solid and dissolved material can absorb UV light.

Your pool water should have a UVT above 90%. If the UVT drops below 90%, the UV treatment may not be effective.

Copper and silver from ionisers will reduce the UVT of the pool water, ensure that levels are kept to a minimum and UVT remains above 90%.

Certain water sources such as bore water may have high metal content and generally poor UVT. Check your water source carefully and ensure that the UVT is high.

6. OPERATION

6.1 Power On

1. Power on the device and the UV-C lamp will slowly illuminate and there will be visible light come out from the transparent cover.
2. For the Ozone model, adjust the venturi tube valve to have the manometer reading 9~14 psi. Use the finger to cover air mesh to feel suction pressure is available.

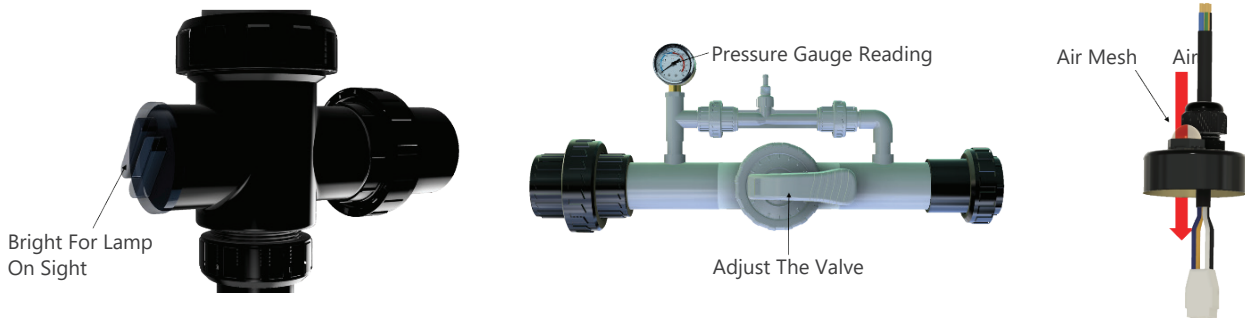

6.2 Digital Timer

The following three functions are available thanks to the digital timer :

1. UV Lamp lifetime meter
2. Schedule timer
3. Clock

As the PuraShield UV is equipped with a flow switch, it is not necessary to use the digital timer. The UV lamp will automatically activate when the water flow starts and deactivate when the water flow stops. The pool filtration pump will typically be controlled via the timer in the primary sanitizer (e.g. salt chlorine generator). So it is not necessary to use the built in clock and timer.

You may choose to use the clock and timer to limit the operating hours of the UV, if the filtration pump runs for an extended period, longer than what is required to treat the water with UV. Doing so could allow the UV lamp to last longer.



6.3 UV Lamp Lifetime Meter

As soon as the above mentioned model with Timer is switched on, the program will carry out a self-test. The display will automatically show the following code: 8888 (display test); software version number; 50Hz or 60Hz indication of the mains frequency.

Following this, the display will show the meter reading:

1. When the UV-C lamp is switched on for the first time, or after the 'Reset' function has been used, the value '9000' will appear on the display. A dot next to the digit on the far right of the display will blink every second: this indicates that the counter is running.
2. If the UV-C system was used previously, once it is switched on again the display will indicate the last value before it was switched off. If you increased or reduce the value of the meter manually, the display will indicate the latest counter reading before it was switched off.
3. The lamp life is actually 10,000 hours for UV + Ozone and 12,000 hours for the 130W Amalgam unit, but the counter is set to 9000 hours, so that there are additional hours of remaining life in the lamp to allow time to organise a replacement.

6. OPERATION

Manual Adjustment:

1. Press the button 'MENU' and select the option 'Hr' by pressing 'MENU' again.
2. The flashing number shown on the screen will indicate the hours left for replacing the lamp.
3. Press the button 'MENU' to modify the hours.
 - 3.1 Use the buttons ▲ and ▼ to increase or decrease the counter value in steps of 500 hours from the initial value up to the maximum value of 9500 and the minimum of 500.
 - 3.2 Once to the desired hour is reached, stand off for 10 seconds until it stops flashing and confirm the set hour chosen.

The time meter will indicate in the following manner that the lamp must be replaced:

1. From hour position 0672, the display will blink every second. Purchase a replacement UV lamp.
2. From hour position 0336, the display will blink every half second.
3. From hour position 0168, the display will blink every 1/4 second.
4. At an hour position of 0000, the digits will blink continuously, and the meter will not continue to count down. It is ready to change the UV lamp now*.

* There is approximately another 1000 hours life left in the UV lamp. If the system is constantly monitored, you can manually adjust the timer to 1000. Otherwise it is recommended to change the lamp now, to ensure the lamp output remains optimal.

6.4 Clock Setting

This function allows you to set the clock according to the current time.

1. Press the button 'MENU' and use the buttons ▲ or ▼ until you reach the option 'rest'. Press 'MENU' to select.
2. The hour indicator will flash. Press ▲ or ▼ to select the desired hour. Wait for 10 seconds until it stops flashing to confirm the hour.
3. Press 'MENU' to select the minutes, and minute indicator will flash. Press ▲ or ▼ to select the desired value. Wait for 10 seconds until it stops flashing to confirm the settings.

6.5 Schedule Timer Setting

This function allows you to schedule the working hours desired for the proper disinfection of the pool. It must be set in every hour.

1. Press the button 'MENU' and use the buttons ▲ or ▼ until you reach the option 'UV'. Press 'MENU' to select.
2. 'UV00' means midnight 00:00h; Press ▲ or ▼ to change the time from 0h to 24h. 'UV01' means 01:00am; 'UV02' means 02:00am, etc.
3. Press the button 'MENU' to select the hour.
4. The selected hour will be flashing. Press ▲ or ▼ to select if at this hour the device will be switched-on or off. Wait for 10 seconds until its tops flashing and confirm the selection.
5. Press the button 'MENU' if you want to go back or select another hour. Check Timer Setting
6. If the working hours has been set, follow the steps to check schedule status.
7. For example, press 'MENU' and press ▲ or ▼ until option 'UV' display,
8. Press 'MENU' and press ▼ to select 'UV05',
9. Press 'MENU' and display flashing 'OFF', it means switched off at this hour. If 'ON' is flashing, it mean "ON" at this hour.
10. Press 'MENU' again and repeat the same procedure to check other hours.

6.6 Flow Switch

These models are supplied with Amalgam UV Lamp recognized as the strongest in the UV-C market. Consequently, it is very important that the lamp works always with a minimum flow rate. For that reason, the flow switch installed in the chamber will automatically switch the device off if no water is flowing through it.

7. MAINTENANCE

To ensure the correct operation and a long life of this UV-C system, regularly check the chemical parameters and maintain them within the recommended range:

1. pH: 7.2 –7.6
2. Total alkalinity: 80 – 120ppm
3. Hardness: less than 120ppm
4. Turbidity: less than 1NTU
5. TSS (Total suspended solids): less than 10mg/l
6. UV Transmittance: more than 90%.
7. For PSUV-87-03, UV + ozone model, clean the air mesh to allow enough air flow into the system to generate O₃-zone.
8. Check the flow switch is functioning by powering off the pump to stop water flow circulation. Check the UV lamp is off from viewing through the transparent cover.

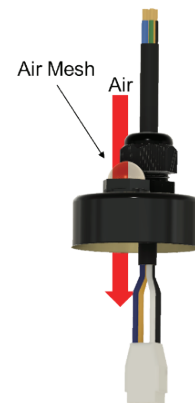

7.1 Lamp & Quartz Glass Maintenance / Replacement

The device must be cleaned twice a year. If there is an increase in algae and / or scale, the quartz glass tube in which the lamp is positioned must be cleaned using a soft cloth with spirit vinegar or acid.

Fouling of the quartz sleeve will occur due to the mineral content of the pool water. High mineral content water and use with copper/silver ionisers may increase the fouling of the quartz glass. This may require more frequent cleaning of the quartz sleeve. The condition of the quartz sleeve should be checked during regular maintenance.

The UV-C lamps must be replaced once the lifetime comes to the end. Please refer to the following table:

Model	Lamp Lifetime (Operating Hours)
PSUV-130	12,000 hours
PSUV-87-03	10,000 hours
PSUV-75	9,000 hours

Fouled or stained quartz sleeves are not covered by warranty and should be cleaned / replaced during regular maintenance.

Always switch off the power supply when replacing the lamp. If necessary, consult the spare parts drawing during replacement, maintenance or dismantling.

The procedure for replacing the lamp is as follows:

1. Stop the circulation pump so that no water is flowing into the unit.
2. Allow the ultraviolet lamp to cool for at least 30 minutes before handling.
3. Un-tighten the external union nuts, and drain the water from the device.
4. Un-thread the top union nut with the cable and carefully remove the lid with the cable gland from the housing.
5. Helped by the own cable, remove the lamp from the UV-C system through the central hole in the quartz glass holder. As these parts are very fragile, caution is essential. Do not touch the lamp with bare hands; use a soft cloth or cotton gloves to handle the lamp. If the lamp has been touched, it is recommended to clean it again using a soft cloth and some alcohol.
6. If the quartz glass needs cleaning or replacing, un-thread the quartz glass holder and carefully remove the quartz glass with the sealing ring. Use a soft cloth or cotton gloves to handle the quartz glass. If it has been touched, it is recommended to clean it again using a soft cloth.
7. Introduce the cleaned or a new quartz glass. Ensure that it is introduced exactly in the initial position. Do not forget the sealing ring on the top of the quartz glass.
8. Hand-tighten again the quartz glass holder and introduce the new lamp carefully into the quartz glass through the same hole in the quartz glass holder.
9. Install the cable gland for water proofing to the lamp cable and thread the external union nuts.

7. MAINTENANCE

7.2 Stainless Steel Housing Maintenance

The stainless steel interior can be cleaned with a soft brush. First of all, the UV-C and quartz lamps have to be removed following the below steps:

1. Un-thread the adaptor male - male 2 1/2" - 2". Remove the sight glass from the opposite side of the adaptor. There are two more threaded adaptors inside the connections. These adaptors make the stainless steel housing holes to be aligned with the connections and sight glass. These two adaptors are placed in the thread of the connection and in the thread of the sight glass.
2. Un-thread the main union nut from the stainless steel housing, and remove the pressuring connector from inside the nut.
3. Remove the PVC tee connections from the stainless steel housing using a plastic hammer.
4. Remove the sealing ring from the stainless steel housing.
5. Clean stainless steel housing and then assemble the UV-C system again:
 - 5.1 Introduce the sealing ring on the stainless steel housing.
 - 5.2 Assemble the PVC tee connections taking into consideration that the connections must coincide with the holes of the stainless steel housing.
 - 5.3 Assemble again the pressuring connector and all the union nuts properly. Note that the adaptors that keep the position of the connections aligned with the stainless steel housing have to be threaded in a specific position so that the two holes can be used for an unscrew to help you to thread the adaptor.

7.3 Electrical Unit Replacement

If the electrical unit needs to be replaced, first of all the earth connection must be disconnected from the electrical housing. The entire ballast box must be unscrewed and the earth wiring must be disconnected from the device.

Unscrew the screw of the ballast box and carefully disconnect the lamp holder from the lamp.

All these parts must be carefully kept, as they are not supplied with the new housing or electrical unit.



7.3.1 Electrical Wiring

WARNING: The unit has power cord with plug attached. Plug it to a power socket with a Residual Current Device (RCD) having a rated residual operating current not exceeding 30mA.

If the RCD device trips, it means there is fault on the power line grounding. Do not use this unit. Disconnect the power and have the problem corrected by a qualified service representative before using. Press the reset button to reset the RCD devices after fixed. It will keep the circuit shut off and will not reset if the power line problem is not fixed. It is recommend to test the RCD at least once a month.

RCD



7. MAINTENANCE

7.3.2 Controller PCB

The power cord Live connect to L and Neutral to N of the PCB upper terminals. The power output of the PCB has the same Live and Neutral colour wire to the UV-C lamp ballast.

Don't un-wire the lower 2 position terminal white colour wire. It is for with flow switch version connection to stop the lamp when there is no water inside the piping to prevent UV-C lamp over heat without water cooling.

There is a CR2032 button size battery for timer setup memory.

Timer version - remove the white colour jumper and connect the flow switch red and black cable.

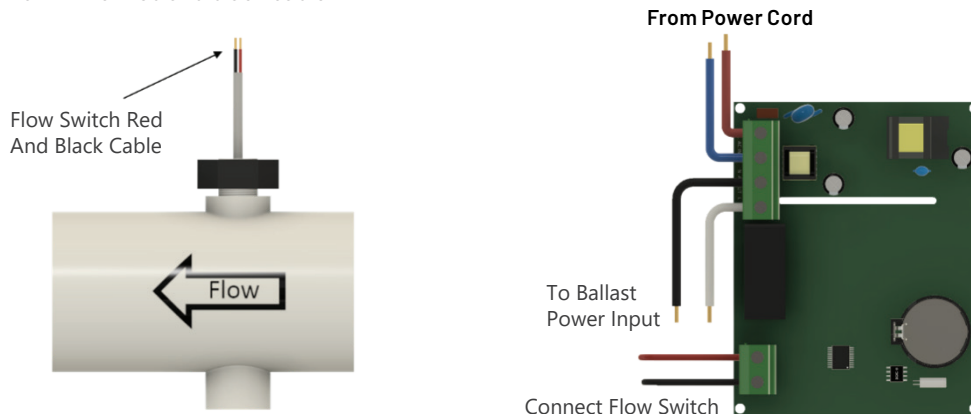

7.3.3 Ballast Connection

The Output L and N of the controller PCB connect to the power input of the ballast according to the pin definition Live, Neutral and Ground. The other side ballast output has four pins for UV-C lamp connection.



Figure 14. Yellow colour output connect T5 lamp socket blue and brown wire with crimp

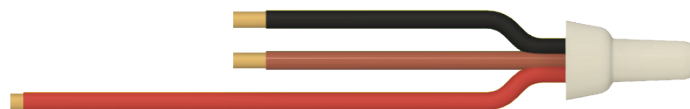
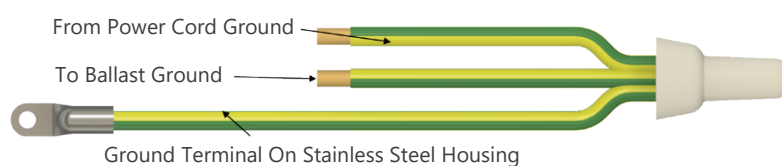

Figure 15. Red colour output connect T5 lamp socket black and yellow green wires with crimp

7.3.4 Grounding

There is a ground crimp with three yellow / green wire, one is from the power cord (earth), one is to the ballast ground terminal and one connect to the stainless steel housing outside the ballast plastic housing.

Loss of any grounding will trigger the RCD and stop the power when power on. It is use to protect from personnel electric socket.



7. MAINTENANCE

7.3.5 Lamp Socket

It is a T5 type lamp socket and be careful to plug the lamp in right orientation to prevent the lamp's connect pins broken. Don't force the lamp pin into the lamp socket. Ensure the lamp and socket is well connected to prevent the lamp loose and damage before insert to the stainless steel body.

For PSUV-87-03 Ozone model, the UV-C lamp is designed dedicate. Replacement of any other brand name model has to been consulted your dealer for confirmation. It will affect the ballast and O-zone generation quantity.



UV-C Lamp Socket Assembly

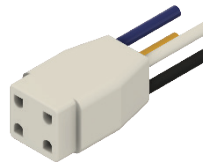

T5 Socket Cable Wiring Colour Scheme



3 Pins UV-C Lamp

8. TROUBLESHOOTING

Symptom	Possible Solution
UV-C system failure, possible lamp disconnection	Disconnect the power cord from the electrical outlet, disassemble the lamp and verify if the lamp connector is fixed firmly in place.
	Verify if the electric cable is connected into an electrified circuit. Test the electrical circuit.
	Make sure you have not connected the device into any power source other than specified on the unit's label. If you have done so in error, the electrical unit might have been damaged and should be replaced. Contact your supplier for the replacement (Not warranted).
The UV Lamp no longer lit	Verify that the electrical outlet where the UV-C System is plugged into has the proper voltage and the cable is securely plugged into the outlet.
	The lamp has burned out. Replace the UV Lamp.
	The electrical unit has burned out. Contact your supplier for the replacement.
	Check the timer setting. It can be at "OFF" schedule.
Pool water is green	Check the chemical balance of the pool.
	Check the UV-C system to make sure it is on.
	Run the UV-C system and the circulation pump longer. If the UV system is operated by a timer, increase a number of working hours.
	Consider replacing the UV Lamp. After 4500 hours of operation, the lamp efficiency drops up to 80%. This is normal for all low-pressure type UV Lamps.
	Clean the air mesh for O-zone model to ensure air flow is enough.
UV-C system makes noise when operating	Check all connections and sealing rings, especially those near to the UV Lamp and the quartz glass.
	Check the screws on the installation, and pay attention to those vibration points
Water is coming out; the UV-C system is leaking	Check all connections and sealing rings, make sure that all connections are threaded properly.
	Check the quartz glass if it is broken or damaged.

9. SPARE PARTS

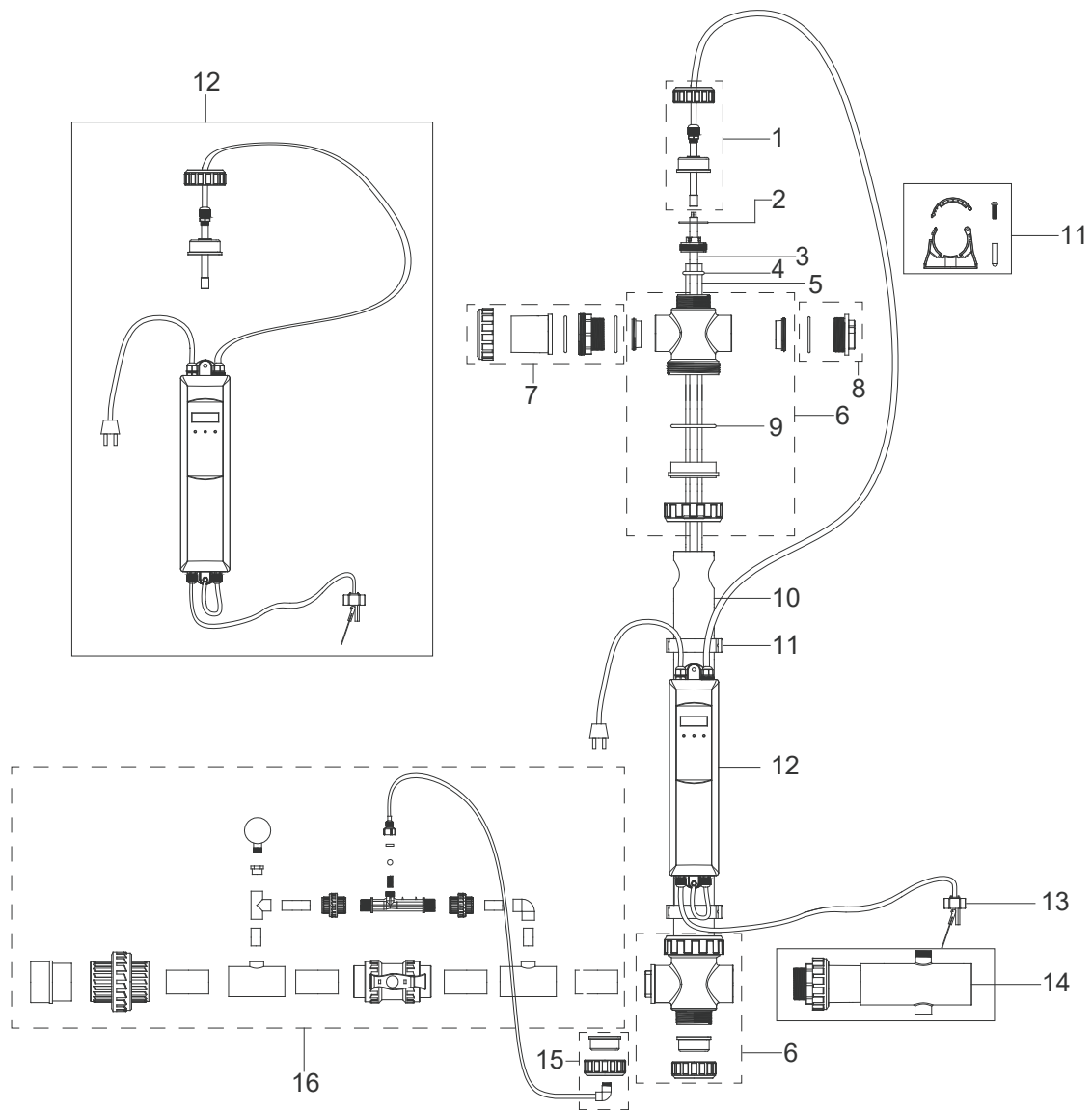

Key No.	Part No.	Description	Qty
1	Adaptor end cap (see ballast kit)		1
2	800841	O-ring lamp connector	1
3	800842	UV Lamp 130W	1
	800854	UV Lamp 87W	1
	800859	UV Lamp 75W	1
4	800843	O-RING QUARTZ SLEEVE 130W 30x6MM	1
4	800855	O-RING QUARTZ SLEEVE 87W 24.8X5.2MM	1
5	800844	QUARTZ SLEEVE 130W	1
	800856	QUARTZ SLEEVE 87W	1
	800860	QUARTZ SLEEVE 75W	1
6	800845	CROSS ADAPTOR KIT	2
7	800755	UNION KIT	2

Key No.	Part No.	Description	Qty
8	800846	SIGHT GLASS KIT	2
9	800847	O-RING UV BODY 76x6MM	1
10	800848	Stainless steel body	1
11	800849	PIPE CLAMPS	2
	800850	UV BALLAST KIT 130W	1
	800851	UV BALLAST KIT 87W	1
12	800862	UV BALLAST KIT 75W	1
13	800858	Flow switch	1
14	800861	Flow Switch Housing	1
15	800863	Ozone Nozzle and Cap	1
16	800857	Ozone Venturi Kit	1

PROPER DISPOSAL OF THIS PRODUCT

This symbol on the product, or in its packaging, indicates that this product may not be treated as household waste. Instead, it should be taken to the appropriate waste collection point for the recycling of electrical and electronic equipment. By ensuring this product is disposed of correctly, you will help prevent potential negative consequences for the environment and human health, which could otherwise be caused by the inappropriate waste handling of this product.

For more detailed information about the recycling of this product, please contact your local council, your household waste disposal service or the shop where you purchased the product from.



1-21 Monash Drive | Dandenong South, VIC 3175 | Australia | 1300 137 344 | pentairpool.com.au

Information contained here-in remains the property of Pentair under Australian copyright law. Content may not be reproduced or transmitted without our prior written permission.

Disclaimer: Pentair reserves the right to change product specifications and products details. Product images are for reference purposes only and may not represent the actual/current product.

©2026 Pentair. All rights reserved.