



FREEFLO

SALT CHLORINATOR

Owner's Manual



FFCL-15-RPD
FFCL-25-RPD
FFCL-35-RPD
FFCL-50-RPD

PENTAIR ONGA FREEFLO SALT CHLORINATOR

Foreword

Congratulations on purchasing a Pentair Onga FREEFLO Salt Chlorinator for your swimming pool. This system is designed for robust reliability and easy operation to give you many years of trouble free service.

Please read the instructions thoroughly before operating your unit. If you have any concerns or require any further assistance, then please do not hesitate to contact our friendly staff or any of our Pentair distributors.

Chemicals

It is important to note that the Pentair Onga FREEFLO Salt Chlorinator does not maintain the water chemistry of your swimming pool water; it simply produces chlorine from a mild salt solution. To ensure that your chemical balances are within the guidelines listed below you should also have your water tested regularly at your local pool shop to encourage a sparkling clean healthy pool.

PH	7.2 – 7.4
Total Alkalinity	90ppm – 150ppm
Cyanuric Acid	40ppm – 65ppm
Salt	4000ppm
Chlorine	1.5ppm – 2.0ppm
Calcium hardness:	200-400ppm

For the best chlorine results in a balanced pool a salt level of 4000 parts per million (ppm) is required. This is easily achieved by using the formula below or approximately 20kg of salt per every 5000 litres.

For example:

Pool volume = Length x Width x Average Depth x 1000
= 9m x 4m x 1.5m x 1000
= 54000 litres

Salt required = Pool Volume x 4 (salt level required, 4000ppm)
1000
= 54000 x 4 / 1000 = 216kg
Or 11 x 20kg bags of pool salt

NB: Before adding salt to your swimming pool, please make sure your Pentair Onga FREEFLO Salt Chlorinator is switched off to avoid overload damage. **THIS WILL VOID ALL WARRANTY.** It is recommended to manually add chlorine to your swimming pool on initial startup as a Salt Chlorinator is designed to maintain chlorine levels and not run for unnecessary long hours to try to build an acceptable chlorine level. The manual addition of chlorine may also be required for unforeseen situations where your swimming pool has required a high chlorine demand, for example after large bather load.

TABLE OF CONTENTS

	Page
FREEFLO Salt Chlorinator Overview	2
Cell Housing Installation	
Installation No Heater	4
Installation With Heater	5
Installation With Solar	5
Installation With Automation - Single Speed Pump	6
Installation With Automation - Intelliflo Variable Speed Pump	6
Power Pack Installation	7
Functions	7
Time Settings	
Setting the Digital Clock	8
Setting the Digital Timer	8
Boost Function	8
Maintenance	9
Troubleshooting	10
Spare Parts	11



CELL HOUSING INSTALLATION

The electrolytic cell housing must be plumbed into the return line after the filter. Please see the installation diagram, Fig.1, below for the preferred method. If a heater is plumbed into the system then the cell housing must be installed after the heater in the return line with a check-valve between the heater and the chlorinator to protect the elements or heat exchanger. If a solar heating system is installed then the cell housing should be fitted after the line going up to the roof and after the return line coming back from the roof if it rejoins the main swimming pool return. The cell housing has allocations for either 40mm PVC pipe or 50mm PVC pipe with the use of the supplied PVC reducing bushes.

-- Please note the installation position of the electrolytic cell for water probe positioning --

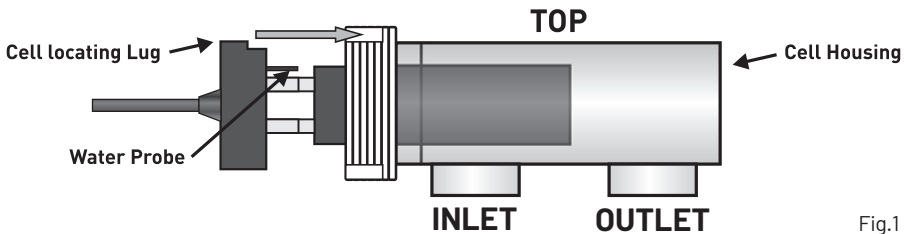

Fig.1

Installation No Heater

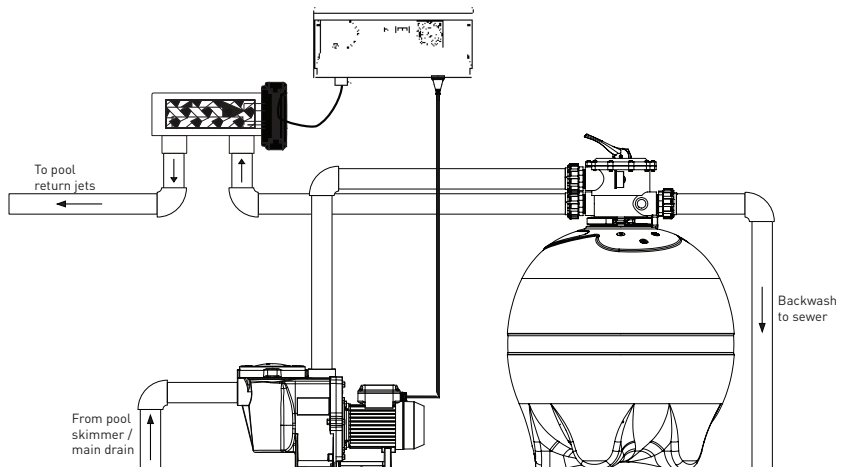

Fig.2

Installation With Heater

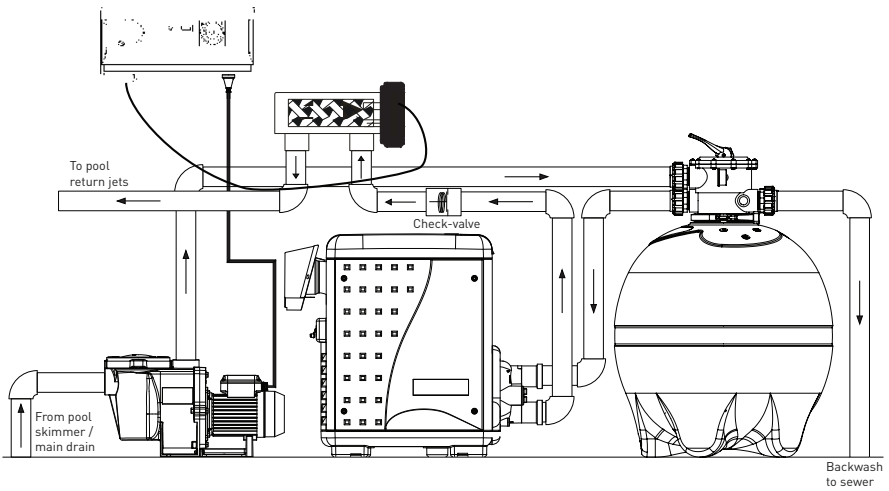

Fig.3

Installation With Solar

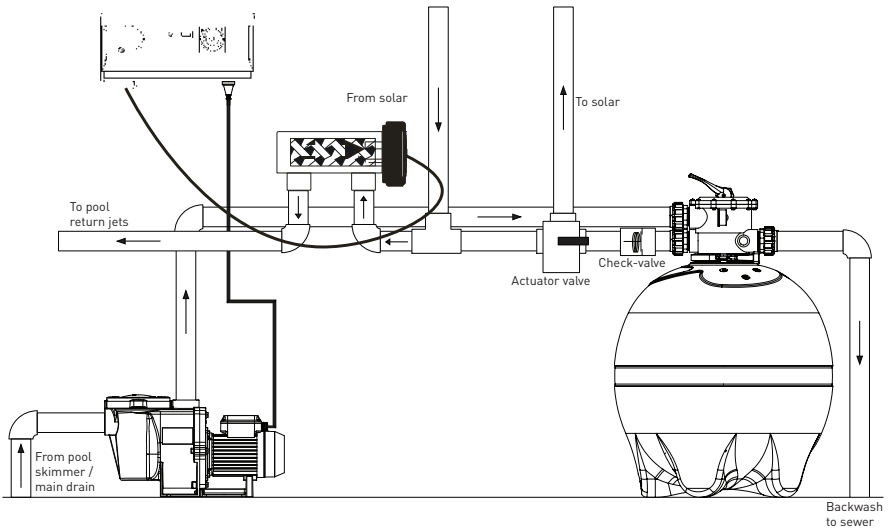

Fig.4

Installation With Automation - Single Speed Pump

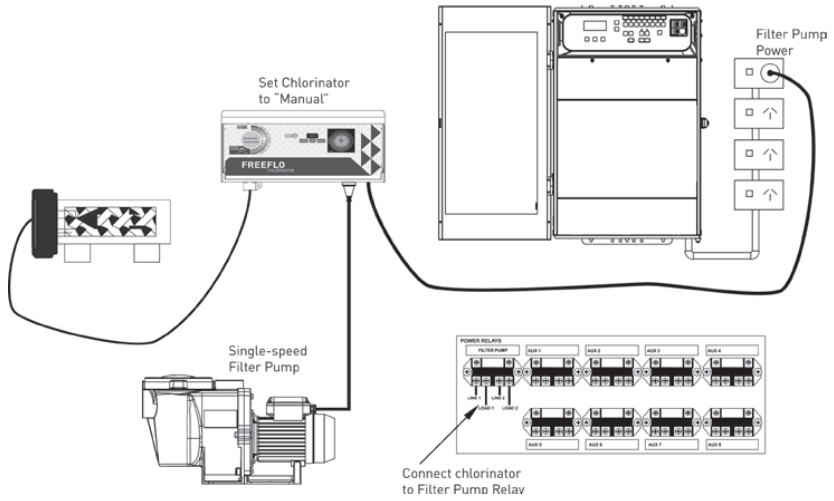

Fig.5

Installation With Automation - Pentair Variable Speed Pump

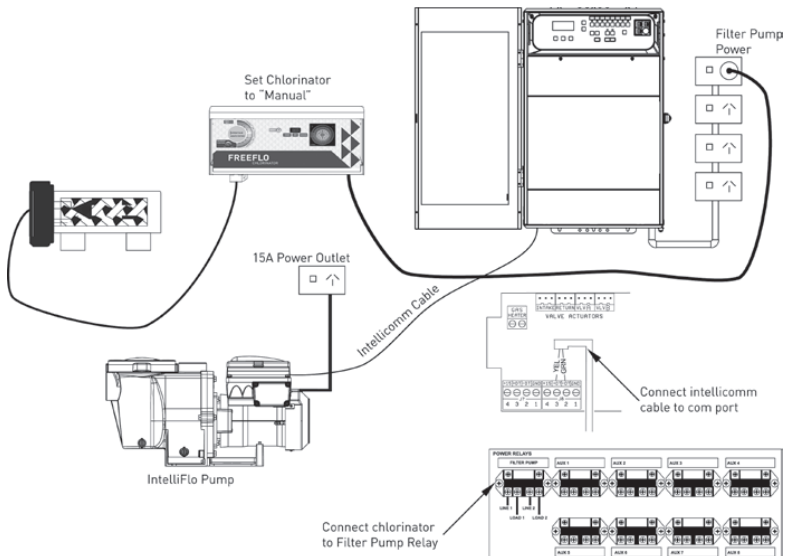

Fig.6

POWER PACK INSTALLATION

Mounting the Pentair Onga FREEFLO Chlorinator power pack is done by either using the supplied mounting bracket or directly hanging on the wall with screws. If mounting directly on the wall, use the guide notches on the top vents to position the holes for installation. The chlorinator power pack is to be mounted at least 800mm above ground level. It is strongly recommended that the unit be installed where it is protected from the elements. Rain and sunlight will prematurely age your unit. It should also be mounted in a position where it is away from accidental water spray. The unit should be installed so that adequate air flow can circulate freely around the power pack to allow the chimney drafting effect to perform efficiently.

FUNCTIONS

All Pentair Onga FREEFLO Chlorinators are fitted with a 240v 10A power socket located on the right hand underside of the power pack. Your pool pump should be plugged into this socket so that the chlorinator and pump activate together when the timer switches on at the allocated time settings or in a model without a timer the pump and chlorinator is controlled by the on/off switch. (7 in Fig.7). Failure to plug the pool pump into this socket could lead to the chlorinator staying on with no water circulation. In case of water probe failure, over heating and a possible gas build up may occur. Please see Fig.7 below in regards to function control.

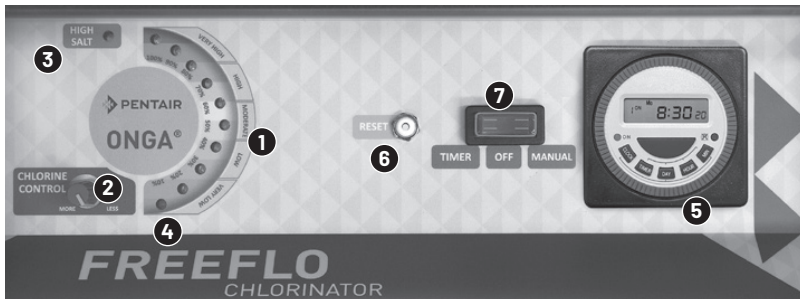

Fig.7

1. Chlorine Output LEDs - If the correct salt level is in the pool then all 10 lights will illuminate. Each light represents 10% chlorine output. If all lights are not illuminated then a higher salt level will be required. Make sure all salt is dissolved properly before adding more. The chlorine control, (2 in Fig.7), will increase or decrease the chlorine output to suit your chlorine demand. If all of the indicator lights flash then there is a water fault problem.

2. Chlorine Control - The chlorine controller determines the amount of chlorine production. By simply turning the control anti-clockwise you increase the chlorine output and by turning the control clockwise you reduce the chlorine output. Do not force the control past its stop as this will damage the unit and void warranty.

3. High Salt Light Illuminated - This light is a red warning indicator and will illuminate when the swimming pool salinity level is above 6,000ppm. If this light is on, together with the ten output LEDs (1 in Fig.7), the salinity level is higher than necessary. The salt chlorinator will continue to function at this level, however it is recommended that the salt level in the pool be reduced to ensure there is no damage to other pool equipment. Verify the salt level with a water test and reduce the salt level by sending some pool water to waste and topping up with fresh water.

High Salt Light Flashing - If this light is flashing, without the output LEDs (1 in Fig.7), the salinity level is extremely high. The salt chlorinator will turn off output. The salt level in the pool must be reduced to ensure there is no damage to the salt chlorinator or other pool equipment. Verify the salt level with a water test and reduce the salt level by sending some pool water to waste and topping up with fresh water.

4. Polarity Light - The polarity light is the first indicator light, 10% in the chlorine output array, (4 in Fig.7). This light will alternate between orange and green every reversing cycle, 4-12 hours. Factory setting is a 12 hour cycle.

5. Timer - The time clock is designed for control of the chlorinator and circulation pump.

TIME SETTINGS

Setting the Digital Clock

Press and hold the **CLOCK** button. Press the **DAY** button until the correct day is displayed. Do the same with the **HOUR** and **MIN** buttons to set the clock.

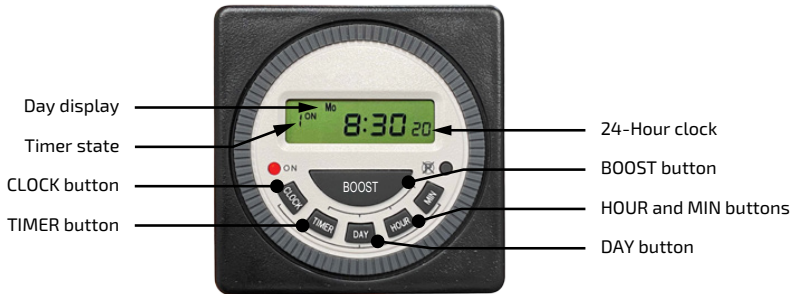

Fig.9

Setting the Digital Timer

To set the chlorinator scheduled ON/OFF times, press the **TIMER** button. The first ON time (1^{ON}) will appear on the screen. The Digital Timer has 10 inbuilt operation-day program settings. Press the **DAY** button to scroll through these programs. Generally, the every-day program should be selected (Mo Tu We Th Fr Sa Su). This will enable the chlorinator scheduled ON/OFF times to activate every day.

Press the **HOUR** and **MIN** buttons to set the ON time. Press the **TIMER** button again, the first OFF time (1^{OFF}) will appear on the screen. Press the **HOUR** and **MIN** buttons to set the OFF time.

Pressing the **TIMER** button again will show the second ON time (2^{ON}). Repeat the programming procedure above to complete additional ON/OFF schedules if required. When finished programming the schedules, press the **CLOCK** button to return to the home screen. On this screen, the current timer state is shown.

To reset a timer schedule, go to the schedule by pressing the **TIMER** button as required, then press and hold the **TIMER** button again to reset.

Boost Function

The **Boost Function** is used to raise the free chlorine level in the pool quickly by running the chlorinator and circulation pump for an extended period. This can be useful after heavy pool use, heavy rain, when algae growth is present or when chlorine levels are low for other reasons.

There are three Boost modes: **6**, **12**, and **24 hours**. To activate a Boost mode, press the **BOOST** button once for 6 hours, twice for 12 hours, three times for 24 hours. A countdown timer will begin for the Boost mode selected. The chlorinator will remain on until the Boost cycle is finished, and the Timer will then revert to the set **ON/OFF** schedules and display the home screen.

Only the **BOOST** button will function during a Boost cycle. If the **BOOST** button is pressed during a Boost mode, the countdown cycle will end, and the Timer will revert to the set **ON/OFF** schedules and display the home screen.

MAINTENANCE

Correct pool water chemistry is important and regular testing should be carried out. In areas where pool water quality is poor some calcium build up may occur on the cell plates. This may require periodical cleaning in a mild hydrochloric acid solution. For more details contact your local pool shop or pool maintenance technician.

When cleaning the cell you must turn the chlorinator off or it will damage your unit and void warranty. Do not use any utensils or harsh chemical cleaners to remove any calcium buildup from the cell as it will damage the cell's semi precious coating and void warranty.

The chlorinator power pack should only be serviced by qualified electrical technicians. For your nearest Pentair recommended service technician, please contact us (see contact details at the back page of this manual).

TROUBLESHOOTING

FAULT / PROBLEM	POSSIBLE CAUSE	REMEDY
No flow. All chlorine output LED's flashing as per page 4, note 1.	Pump turned Off.	Ensure pump is turned ON.
	Closed valve.	Open valve.
	Air in system.	Check all O-rings & grease.
	Dirty filter.	Clean or backwash filter.
	Low water level.	Fill up pool.
	Calcium build-up on water probe sensor.	Clean probe in a mild hydrochloric acid- ref. page 4.
High Salt Red LED illuminated.	Salinity level higher than required >6000ppm	Recommend reducing salt level of pool.
High Salt Red LED flashing.	Salinity level higher than 10,000ppm	Reduce salt level of pool.
No lights.	Circuit Breaker tripped. Fig 2. Note 6.	Reset Circuit Breaker as per page 8, note 6.
	Mains power failure.	Check switches and switchboard circuit breaker.
Low / No chlorine production.	Chlorine output too low.	Increase chlorine production as per page 7, note 2.
	Salt level too low.	Increase salt level to 4000ppm and check stabiliser (Cyanuric) levels.
	PH too high.	Adjust PH between 7.2-7.4
	Timer period too short.	Increase running time.
	High phosphate levels.	Add starver.
	Cell connection.	Check connection at the junction box on the underside of the unit.
Abnormal calcium build-up in cell.	Calcium levels in swimming pool water extremely high or water chemistry.	Reduce calcium level in pool. Lower water level and fill with clean water. Use a calcium reduction agent. Clean cell with mild HCl solution.
Timer times-out of sync.	Timer not set correctly.	Check setting procedure as per page 7, note 5.
	Chlorinator installed on off-peak tariff.	Timer will need battery backup if installed on off tariff.
	Timer / Off / Manual switch not switched correctly.	Make sure switch is selected as per page 8, note 7.
Digital timer displaying "d" on screen and not functioning.	Unused mode entered.	Push the reset button (P), then reset the clock and timers.
OVER TEMPERATURE (LED 1 flashing red and amber)	Unit is installed in an area where the ambient temperature is extremely high.	Supply adequate cooling. Install outside of the extreme temperature area.

SPARE PARTS

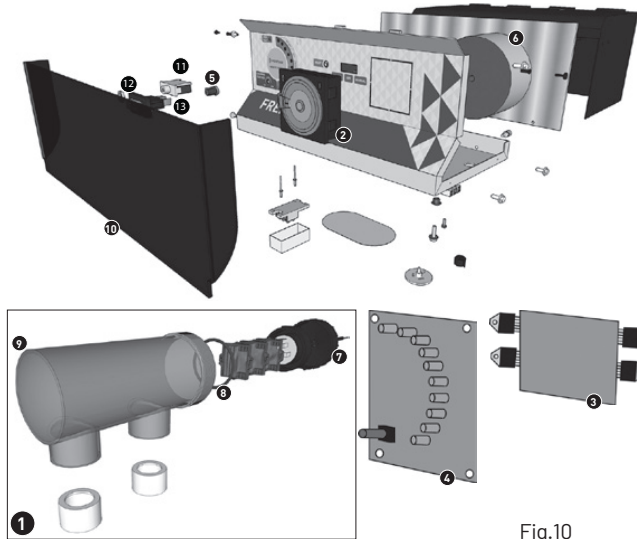

Fig.10

Item	Part No.	Description
FREEFLO SALT WATER CHLORINATOR PARTS		
1	801933	Replacement Cell 15g (3 Plates)
1	801934	Replacement Cell 25g (5 Plates)
1	801935	Replacement Cell 35g (7 Plates)
1	801972	Replacement Cell 50g/hr
2	801974	Battery Back-up Time Clock with Wire Kit (Digital)
3	801937	Power PCB Kit
4	801938	Control PCB Kit
5	801939	Control PCB Knob
6	801940	Transformer
7	801941	Cell Lock Nut
8	801942	O-ring Cell Union
9	801943	Cell Casing
10	801944	Perspex Cover
11	801948	Overload
12	801970	Rocker Cover
13	801971	Rocker Switch
NOT SHOWN		
	801959	Mounting Plate
	801947	Blanking Cap
	800100	Junction Box
	800116	POWER PACK FREEFLO 15G/HR
	800117	POWER PACK FREEFLO 25G/HR
	800118	POWER PACK FREEFLO 35G/HR

WARRANTY

Your Pentair Onga FREEFLO Chlorinator is covered by a 3 year warranty on the power pack and a 5 year pro-rata warranty on the cell from the date of purchase. The power pack controller and electrolytic cell are covered against defects in materials and assembly from the date of purchase in a domestic application. Warranty will not be given without proof of purchase, so keep your original purchase invoice in a safe place.

Unfavourable environments and operating conditions beyond the control of the manufacturer such as incorrect power supply (must be 230V 50 Hz), the Pentair Onga FREEFLO Chlorinator plugged into an ancillary device such as a Variable Frequency Drive, wear and tear, water and insect damage, extreme ambient temperatures or any other adverse situation that affects the Pentair FREEFLO Chlorinator will void warranty. All warranties only apply if the equipment is installed and operated in complete compliance with the installation and operating instructions.

Pentair Onga FREEFLO Chlorinators and electrolytic cells installed in a commercial situation are covered by a 1 year warranty. Commercial situations meaning motels/hotels, health spas, apartment/town house complexes and any situation with an unusually high bather load or abnormal conditions.

Pentair Australia will not accept liability for any consequential loss or damage of any kind.

FOR ALL WARRANTY ENQUIRIES, PLEASE CALL 1300 137 344.

IMPORTANT

Please attach your sales invoice/docket here as proof of purchase should warranty service be required. Please do not return warranty form to Pentair Australia. Retain for your records.

PURCHASED FROM:
PURCHASE DATE:
SERIAL NO:
MODEL NO:

NOTES

A series of horizontal dashed lines for taking notes.



1-21 Monash Drive | Dandenong South, VIC 3175 | Australia | 1300 137 344 | pentairpool.com.au

Information contained here-in remains the property of Pentair under Australian copyrights law. Any reproduction, display, publication, modification or distribution is strictly prohibited without the prior written permission of Pentair.

Disclaimer: Pentair reserves the right to change product specifications and products details.

All product images are for reference purposes only and may not represent actual and/or current product.

©2026 Pentair. All rights reserved.